

Characterizations of intrinsic volumes on convex bodies and convex functions

Fabian Mussnig¹

If we want to express the size of a two-dimensional shape with a number, then we usually think about its area or circumference. But what makes these quantities so special? We give an answer to this question in terms of classical mathematical results. We also take a look at applications and new generalizations to the setting of functions.

1 What makes area and circumference so special?

If we have an object in two-dimensional space, there are several numbers we can assign to it that express how large it is or that measure its size. The usual area and the circumference are probably among the first ones that come to our minds. But what makes these quantities stand out?

In what follows, we will answer this question for what are called *convex bodies*. These are sets that are both *convex* and *compact*. A set K is convex if for any two points $x, y \in K$, the line segment connecting x and y is inside K , see Figure 1. Compact means that the set is bounded and that it is closed, that is, it is not infinitely large and the boundary is part of the set. In German, convex bodies also used to be called *Eikörper* which roughly translates to “egg bodies”. Indeed, eggs are usually (three-dimensional) convex bodies but not every convex body looks like an egg.

¹Fabian Mussnig is supported, in part, by the Austrian Science Fund (FWF): J 4490-N.

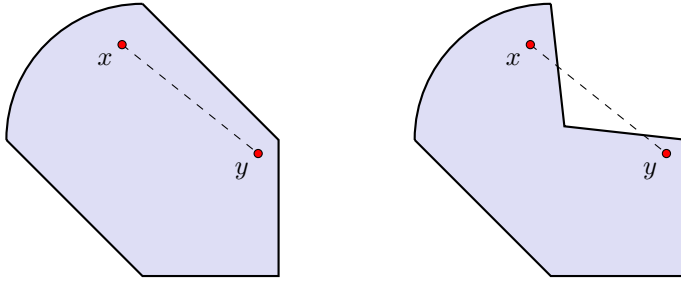

Figure 1: The set on the left is convex. The set on the right is not convex, since the line segment connecting x and y is not inside the set.

1.1 A characterization of area

Let us start with the area. Obviously, the area of a convex body does not change if we move it around in the two-dimensional plane. We thus say that area is *translation invariant*. We may also rotate a body without changing its area. Less obviously, we can even stretch a body in one direction and compress it in another direction while maintaining its area, see Figure 2.

In mathematics these operations on a body are called *special linear transforms* and they are represented by matrices with determinant 1.^[2] Hence, we say that area is *SL(2) invariant*, where $SL(2)$ stands for the group of special linear transforms in two-dimensional space.

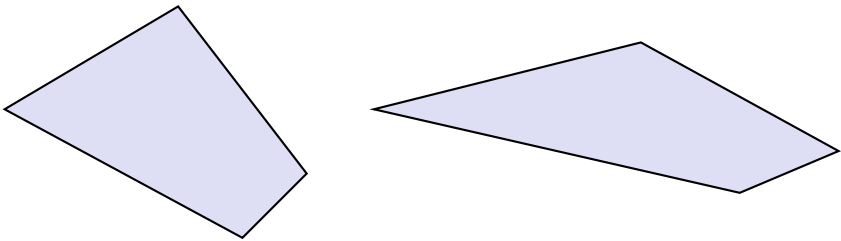

Figure 2: The original set on the left is stretched in horizontal direction and compressed in vertical direction to obtain the set on the right. Both sets have the same area but the set on the right has a larger circumference.

^[2]The determinant of a matrix is a number that captures important information about the transformation that the matrix represents. See, for instance, http://mathinsight.org/determinant_matrix.

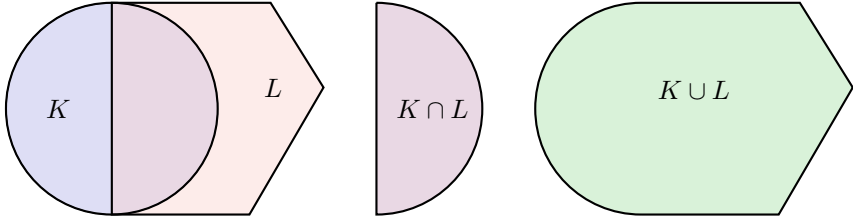

Figure 3: Two convex bodies K and L , their intersection $K \cap L$, and their union $K \cup L$.

Another property of area is that it is continuous. This means that if we change a body slightly, then this will also only cause a small change in its area.^[3] Last but not least, area is a *valuation*. This means that if we take two convex bodies K and L , then

$$\text{area}(K \cap L) + \text{area}(K \cup L) = \text{area}(K) + \text{area}(L).$$

Here $K \cap L$ is the intersection and $K \cup L$ is the union of the bodies K and L .^[4] We illustrate this in Figure 3. In a certain way, this means that area is measuring objects.

In 1937, Wilhelm Blaschke (1885–1962) in [1] answered the following question: What are all the continuous, $\text{SL}(2)$ - and translation-invariant valuations on convex bodies? As we have just discussed, area is one of them. But there is also a very trivial candidate, namely that we assign to each convex body the number 1. This is also called the *Euler characteristic*. The answer that Blaschke found is that any valuation of convex bodies in the plane is either a multiple of the area (for example, assigning to a body 4 times its area is a valuation), a multiple of the Euler characteristic, or a sum of these expressions. So if we write \mathcal{K}^2 for the set of convex bodies in the plane, Blaschke’s result says that every continuous, $\text{SL}(2)$ - and translation-invariant valuation $Z : \mathcal{K}^2 \rightarrow \mathbb{R}$ is of the form

$$Z(K) = c_0 + c_1 \text{area}(K) \tag{1}$$

with $c_0, c_1 \in \mathbb{R}$. This means that Z is a linear combination of the Euler characteristic and the area. Conversely, every expression of the form (1) is a

^[3]To make this more precise, we would need to specify the topology on the set of convex bodies, which is given by the Hausdorff metric. For full-dimensional bodies this is also equivalent to the symmetric difference metric, that is, the area (or more generally, n -volume) of the symmetric difference.

^[4]Usually when we speak of valuations defined on convex bodies, we need to ask that also $K \cup L$ is again convex. However, all the valuations in this article can be extended to finite unions of convex bodies.

continuous, $\text{SL}(2)$ - and translation-invariant valuation. This also means that Blaschke could show what makes area so special. Because apart from the very trivial example of the Euler characteristic, it is essentially the only continuous, $\text{SL}(2)$ - and translation-invariant valuation on \mathcal{K}^2 .

1.2 A characterization of circumference

Next, let us discuss circumference. Clearly it is translation invariant. It is also invariant under rotations, but not under the larger group of special linear transforms, see Figure 2 again. Circumference is also continuous and it turns out that it is also a valuation (at this point it might be a good idea to have a look at Figure 3 again). So similar to Blaschke's result, in the 1950s Hugo Hadwiger (1908–1981) in [4] gave an answer to the question of what all continuous, rotation- and translation-invariant valuations on convex bodies look like. Note that this question is very similar to the one asked by Blaschke, except that $\text{SL}(2)$ invariance is now replaced by rotation invariance. Since special linear transforms are more than just rotations, this means that rotation invariance is less restrictive than $\text{SL}(2)$ invariance and thus we expect more valuations to satisfy these conditions. Indeed, we already know that not only linear combinations of the Euler characteristic and area should appear in Hadwiger's result but also circumference. It turns out that there are no further examples and Hadwiger's characterization theorem in the plane states that a map $Z : \mathcal{K}^2 \rightarrow \mathbb{R}$ is a continuous, rotation- and translation-invariant valuation if and only if there exist $c_0, c_1, c_2 \in \mathbb{R}$ such that

$$Z(K) = c_0 + c_1 \text{circ}(K) + c_2 \text{area}(K), \quad (2)$$

where $\text{circ}(K)$ is the circumference of $K \in \mathcal{K}^2$. We can now further modify this result to obtain separate characterizations of the Euler characteristic, circumference and area, since they have different *degrees of homogeneity*. This means if we scale a body K by a factor $\lambda > 0$, then its area will change by λ^2 . So

$$\text{area}(\lambda K) = \lambda^2 \text{area}(K)$$

and we say that area is homogeneous of degree 2. At the same time the circumference of K will change by λ^1 (so circumference is homogeneous of degree 1), while the Euler characteristic of K will not change at all. See Figure 4. So now we know that circumference is essentially the only continuous, translation- and rotation-invariant valuation that is homogeneous of degree 1.

2 Higher dimensions

While so far we have only discussed the two-dimensional case, everything that we wrote above also works in general n -dimensional Euclidean space. In this

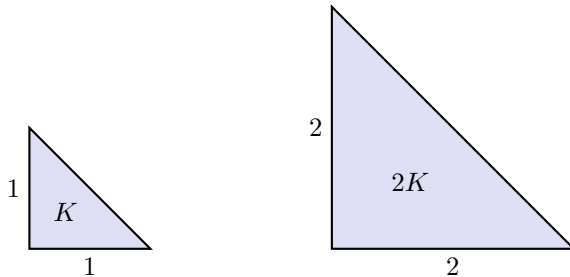

Figure 4: If we scale K by 2, then its area is multiplied by $2^2 = 4$ and its circumference changes by the factor $2^1 = 2$.

case, Blaschke's result remains more or less unchanged: all continuous, $\text{SL}(n)$ - and translation-invariant valuations on convex bodies in \mathbb{R}^n are given by linear combinations of the Euler characteristic and (n -dimensional) volume, which is the generalization of area to n -dimensional space.

In Hadwiger's result for n dimensions we will however obtain linear combinations of a total of $(n + 1)$ different operators: these are the *intrinsic volumes* V_0, \dots, V_n . We have already encountered V_0 and V_n : V_0 is the Euler characteristic and V_n is the n -dimensional volume. That is, if K is a two-dimensional body K , then $V_2(K)$ is its area and if L is a three-dimensional body, then $V_3(L)$ is its usual volume.

The intrinsic volumes V_1, \dots, V_{n-1} need a bit more explanation. If we are in two-dimensional space, then Hadwiger's theorem, now written in terms of intrinsic volumes, tells us that all continuous, rotation- and translation-invariant valuations $Z : \mathcal{K}^2 \rightarrow \mathbb{R}$ are of the form

$$Z(K) = d_0 V_0(K) + d_1 V_1(K) + d_2 V_2(K),$$

with $d_0, d_1, d_2 \in \mathbb{R}$. If we now compare this with Equation (2) and also consider that $V_2(K) = \text{area}(K)$, then we might suspect that $V_1(K)$ is proportional to the circumference of K . Indeed $V_1(K) = \frac{1}{2} \text{circ}(K)$ for $K \in \mathcal{K}^2$.

In three-dimensional space, $V_2(K)$ equals half the *surface area* of $K \in \mathcal{K}^3$ and $V_1(K)$ is proportional to the *mean width* of K . For a more thorough but also very well-presented discussion of intrinsic volumes we refer to the beautiful snapshot by Liran Rotem [5].

3 Applications

Let us briefly take a look at an application of Hadwiger's theorem. For this we consider a convex body K in three-dimensional space. We place a light source

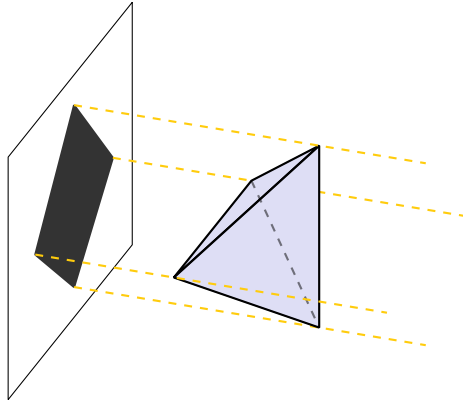

Figure 5: A convex body in three-dimensional space and its shadow. The light source, which is placed to the right of the body and emits parallel rays of light, is not shown.

that emits parallel rays of light on one side of the body and a sheet of paper on the exact opposite side. The body K now casts its shadow on the paper and we can measure its area, which is depicted in Figure 5. We repeat this construction by letting the light source shine onto the body from all possible directions (each time placing the sheet of paper on the exact opposite side) and take an average of the shadow areas that we obtain.^[5] We now claim that we have just calculated the surface area of K (up to a fixed multiplicative factor). How do we know this?

It turns out that the process we have just described (and which ultimately assigns to a convex body a number) is a continuous, translation- and rotation-invariant valuation. Furthermore, it is homogeneous of degree 2. Indeed, if we scale the body K by a factor $\lambda > 0$, then we also scale its shadow by the same factor and the shadow's area changes by λ^2 . Thus, by Hadwiger's theorem for three-dimensional space, this valuation must be a multiple of the surface area.

This alternative way to calculate the surface area of a convex body is also known as Cauchy's surface area formula. It was first proved roughly 100 years before Hadwiger proved his famous theorem. Hadwiger's theorem not only provides a quick explanation of why this formula is true, it also allows us to obtain other, much more general formulas, of a similar spirit.

^[5]Here we really mean all possible directions, which means that the average is taken over an infinite number of possibilities. Formally, this is expressed in the form of an integral.

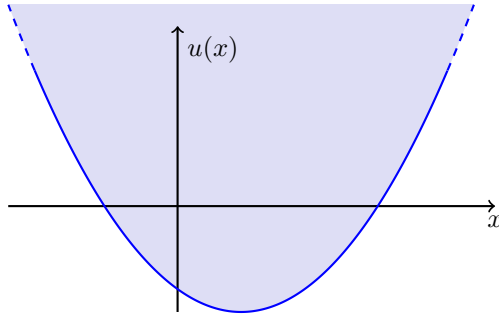

Figure 6: The area above the graph of a convex function $u(x)$ is an unbounded convex set.

4 From convex bodies to convex functions

Next we want to discuss how we can extend intrinsic volumes and valuations from convex bodies to *convex functions*. Roughly speaking, a real-valued function u on \mathbb{R}^n is convex if the area above its graph is a convex set. In two dimensions, this idea is depicted in Figure 6. We will also allow convex functions to attain the value $+\infty$. Among other reasons, this enables us to represent a convex body K in \mathbb{R}^n by its *indicator function*

$$I_K(x) = \begin{cases} 0, & \text{if } x \in K; \\ +\infty, & \text{otherwise.} \end{cases}$$

It is not hard to see that $I_K : \mathbb{R}^n \rightarrow (-\infty, +\infty]$ is a convex function if and only if K is a convex set. Perhaps try to see it for yourself with indicator functions over sets in \mathbb{R} or \mathbb{R}^2 (where it is at least possible to sketch the graph). Our goal now is to find operations on convex functions that generalize intrinsic volumes. This means if we apply such an operation to an indicator function of a convex body K , then we want to obtain an intrinsic volume of K .

4.1 The one-dimensional case

We will demonstrate our ideas in the case $n = 1$, which means that we consider convex functions $u : \mathbb{R} \rightarrow (-\infty, +\infty]$. The convex bodies in one-dimensional space are intervals of the form $[a, b]$ with $a, b \in \mathbb{R}$, $a \leq b$, and each such body is represented by the convex indicator function $I_{[a,b]}$, as depicted in Figure 7. Hadwiger's theorem in the one-dimensional case describes two intrinsic volumes, the Euler characteristic, V_0 , and the usual *length* of an interval, $V_1([a, b]) = b - a$.

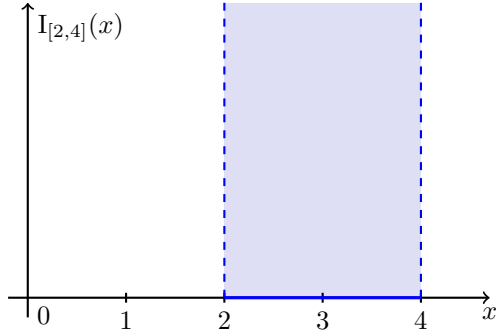

Figure 7: The convex indicator function $I_{[2,4]}$ represents the interval $[2, 4]$. This function is $+\infty$ if its argument is smaller than 2 or larger than 4. For better visualization the area above the graph of $I_{[2,4]}$ is colored.

The functional version of the Euler characteristic is easy to describe: we simply assign to each convex function the number 1. What about length?

Clearly, if we look at the picture of an indicator function $I_{[a,b]}$, Figure 7, then the length of the interval $[a, b]$ is the same as the length of the visible graph of $I_{[a,b]}$. We know from integral calculus that the length of the graph of a differentiable function $f : [a, b] \rightarrow \mathbb{R}$ is given by

$$\int_a^b \sqrt{1 + (f'(x))^2} dx, \quad (3)$$

where the derivation of this formula is depicted in Figure 8. Thus, a naive approach is to simply consider

$$I_{[a,b]} \mapsto \int \sqrt{1 + (I'_{[a,b]}(x))^2} dx = \int_a^b \sqrt{1 + 0^2} dx = b - a,$$

where we only integrate over those points $x \in \mathbb{R}$ where $I_{[a,b]}(x)$ is finite (and thus differentiable). That is, we only integrate over $x \in [a, b]$, for which we always have $I'_{[a,b]}(x) = 0$. We now may try to generalize this and define an operation

$$u \mapsto \int \sqrt{1 + (u'(x))^2} dx \quad (4)$$

for convex functions $u : \mathbb{R} \rightarrow (-\infty, +\infty]$. However, if for example we take $u(x) = x^2$, then we obtain

$$\int_{-\infty}^{+\infty} \sqrt{1 + 4x^2} dx = +\infty.$$

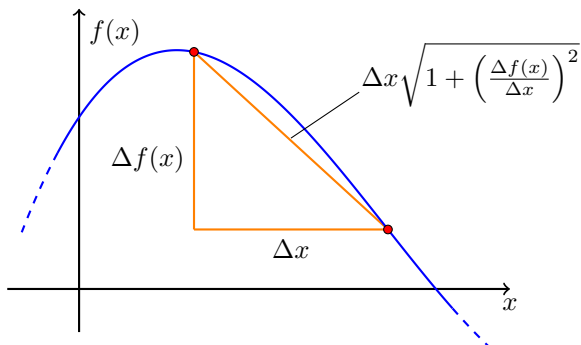

Figure 8: We use the Pythagorean theorem to calculate the hypotenuse of the triangle. We approximate the graph of f with many such triangles, use lower Riemann sums and let $\Delta x \rightarrow 0$ to obtain (3).

In a sense this is expected since the graph of this particular function u has infinite length. The problem is that we would like to obtain a finite number for each function while still retrieving the usual length if we consider indicator functions. In order to solve this problem, we first rewrite (4) as

$$u \mapsto \int g(|u'(x)|) dx,$$

where $g(t) = \sqrt{1+t^2}$. The solution is to now replace g by some other function that has properties that allow us to obtain the result we want. Thus, we consider

$$u \mapsto \int h(|u'(x)|) dx, \tag{5}$$

where $h : [0, +\infty) \rightarrow \mathbb{R}$ is a continuous function with compact support. This means that $h(t) = 0$ for every t larger than some fixed positive number. An example of such a function is depicted in Figure 9. If in addition we ask that our convex functions “go to $+\infty$ fast enough”, similar to $u(x) = x^2$, then one can show that the integral in (5) is always finite. Furthermore, if we choose u to be the indicator function of an interval $[a, b]$, then we obtain

$$\int h(|I'_{[a,b]}(x)|) dx = \int_a^b h(0) dx = h(0)(b-a).$$

This means that for indicator functions we retrieve a multiple of the usual length. Another observation is that if we change u by moving its graph up, down, left or right, we still obtain the same value in (5). This means that our

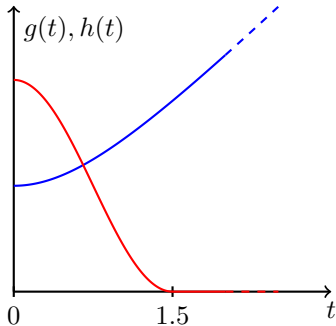

Figure 9: The function in blue is $g(t) = \sqrt{1+t^2}$. The function $h(t)$ in red has compact support and $h(t) = 0$ for every $t \geq 1.5$.

operation is translation invariant in a functional sense. We may also take the reflection of the graph of u with respect to the vertical axis while still obtaining the same value from our operation. Without going into details, it turns out that (5) is also a continuous valuation on convex functions. We have thus found our functional version of the first intrinsic volume.

The main result of [2] for the case $n = 1$ now states that every continuous, reflection- and translation-invariant valuation Z on convex functions $u : \mathbb{R} \rightarrow (-\infty, +\infty]$, that “go to $+\infty$ fast enough”, is of the form

$$Z(u) = c + \int h(|u'(x)|) dx,$$

where $c \in \mathbb{R}$ is some constant and $h : [0, \infty) \rightarrow \mathbb{R}$ is continuous with compact support. This should be understood as a functional version of Hadwiger’s result.

4.2 Higher dimensions and applications

What we have described above also works in higher dimensions. The functional version of the n -dimensional volume is then of the form

$$u \mapsto \int h(\|\vec{\nabla}u(x)\|) dx,$$

where $u : \mathbb{R}^n \rightarrow (-\infty, +\infty]$ is convex and $h : [0, +\infty) \rightarrow \mathbb{R}$ is again continuous with compact support. Here, $\vec{\nabla}u(x)$ is the *gradient* of the function u at $x \in \mathbb{R}^n$, which is a vector that can roughly be described as a higher-dimensional version of the usual derivative. The expression $\|\vec{\nabla}u(x)\|$ stands for the *norm* or *length* of this vector. For $n > 1$ we also find new operations on convex functions that

generalize the intrinsic volumes V_1, \dots, V_{n-1} . However, these operations use second derivatives and are more complicated to describe, so we leave out the details. Again, a characterization of these operations, similar to Hadwiger's characterization of the intrinsic volumes on convex bodies, was found in [2].

Finally, let us mention that in many ways these new functional intrinsic volumes behave like the classical intrinsic volumes. In particular, the new functional Hadwiger theorem can be used to obtain a functional version of Cauchy's surface area formula [3], which generalizes its classical counterpart.

Image credits

All figures were created by the author.

References

- [1] W. Blaschke, *Vorlesungen über Integralgeometrie. H. 2*, Hamburger mathematische Einzelschriften 22, 1937.
- [2] A. Colesanti, M. Ludwig, and F. Mussnig, *The Hadwiger theorem on convex functions. I*, arXiv:2009.03702, 2020.
- [3] ———, *The Hadwiger theorem on convex functions. II*, arXiv:2109.09434, 2021.
- [4] H. Hadwiger, *Vorlesungen über Inhalt, Oberfläche und Isoperimetrie*, Die Grundlehren der Mathematischen Wissenschaften, vol. 93, Springer, 1957.
- [5] L. Rotem, *Mixed volumes and mixed integrals*, Snapshots of modern mathematics from Oberwolfach 14/2018, <https://publications.mfo.de/handle/mfo/1400>.

Fabian Mussnig *is a postdoc university*
assistant at TU Wien, Austria.

License
Creative Commons BY-SA 4.0

Mathematical subjects
Analysis, Geometry and Topology

DOI
10.14760/SNAP-2022-011-EN

Snapshots of modern mathematics from Oberwolfach provide exciting insights into current mathematical research. They are written by participants in the scientific program of the Mathematisches Forschungsinstitut Oberwolfach (MFO). The snapshot project is designed to promote the understanding and appreciation of modern mathematics and mathematical research in the interested public worldwide. All snapshots are published in cooperation with the IMAGINARY platform and can be found on www.imaginary.org/snapshots and on www.mfo.de/snapshots.

ISSN 2626-1995

Junior Editor
Sara Munday
junior-editors@mfo.de

Senior Editor
Anja Ran-decker
senior-editor@mfo.de

Mathematisches Forschungsinstitut
Oberwolfach gGmbH
Schwarzwaldstr. 9–11
77709 Oberwolfach
Germany

Director
Gerhard Huisken



Mathematisches
Forschungsinstitut
Oberwolfach



IMAGINARY
open mathematics